

XF105 series cabs

Exterior



Unmistakable DAF. The modern, elegant looks clearly show the roots of the DAF XF105 cab and its family relationship with the other DAF vehicle series.



The impressive cab design is emphasized by the sturdy lower grille that extends deep over the stylish bumper in cab colour.

The large, almost vertical windscreen offers the driver a superior view of the road ahead.

An excellent and save rear view is obtained from four nicely-shaped mirrors, with covers in cab colour as an option.

The DAF XF105 cab is designed to minimize the risk of minor but potentially expensive damages. The thick steel bumper, shatter and crack resistant body panels and virtually unbreakable Lexan lamp lenses are just some examples.

Evolved from the very succesful DAF XF95 series, the XF105 cab rises to new heights in quality, driver satisfaction and low operating costs.

The impressive cab design is emphasized by the sturdy lower

The rounded mirror covers, the gap behind the sun visor, the air openings in the lower cab front and the corner air deflectors have all been carefully designed to keep the glass surfaces, the mirrors and the doors clear of rain and road spray.

Not only for the driver to keep his hands clean, but also for the purpose of a high-quality impression for the transport company and to enhance the driving safety.

Two versions of the DAF XF105 cab are available. The high-roof Space Cab and the even higher Super Space Cab with class leading spaciousness and the last word in prestigious and purposeful cab design for professional long distance haulage.

The DAF XF105 cab is a true product of world class manufacturing: designed for the highest driver satisfaction, the best operating efficiency and a high prestige for the operator.



XF105 series cabs

Dimensions

Space Cab

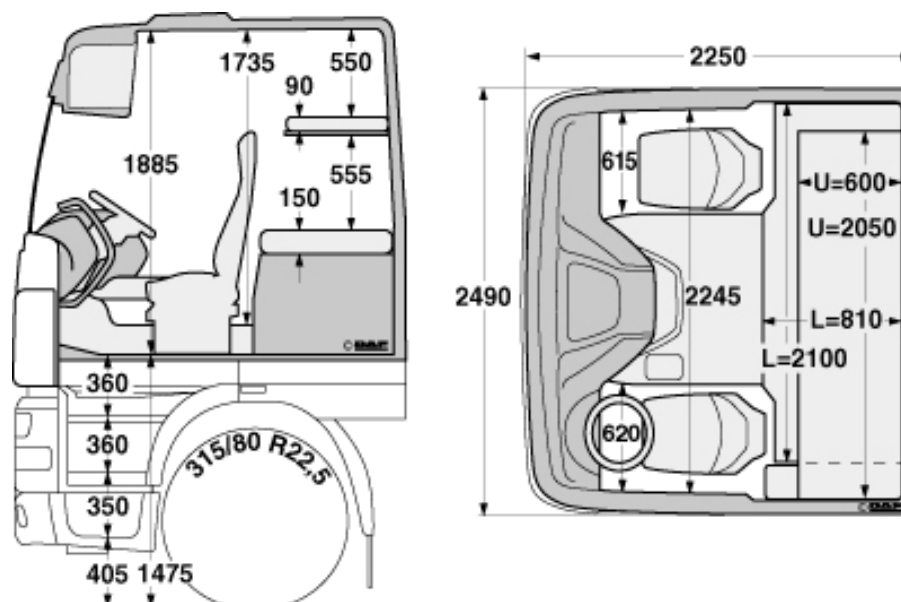

Super Space Cab

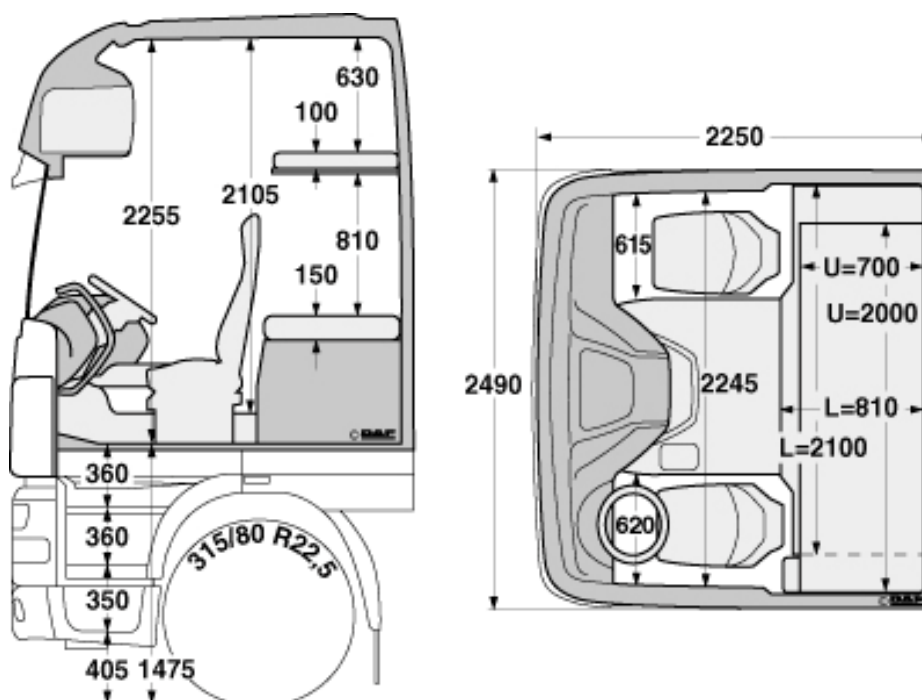

XF105 series cabs

Interior



The DAF XF105 cab interior breathes quality and a well-considered design in every single detail. Consider the clever utilization of the enormous space inside, the harmonious styling, the careful choice of materials and the tasteful colours.

Make yourself comfortable in the luxury seat behind the steering wheel. The elegant dashboard curves around you, with all driving controls within easy reach. The central LCD display keeps you informed about all vital vehicle functions. Notice the three positions for additional equipment in the dashboard wing.



Feel relaxed during night drives with the pleasant indirect amber lighting of the cab floor and ceiling. Experience the freedom of movement on the near flat cab floor, free of obstacles.

Discover the huge volume of smartly arranged storage spaces. Above the windscreen, on the dashboard, in the doors and beneath the lower bunk. The optional refrigerator takes 1-litre bottles in upright position, as does the large bottle holder beside the driver seat.

Sit down on the large lower bunk and extend the table from the dashboard centre console to do some paperwork or to enjoy the meal you just prepared in the microwave oven, that is easily stored in the overhead locker.

Stand upright on the low engine tunnel and move freely as you wish to change clothes for the night.

Sleep comfortable like at home on the commodious lower bunk with its one-piece 15 cm thick pocket sprung mattress.





Your co-driver may use the comfortable aluminium fold-away step and sleep on the 2 m long one-piece upper bunk mattress.

The DAF XF105 cab is a place where every driver immediately feels at home. The best place to drive, live and sleep in.

XF105 series cabs

Specification

Exterior / Interior / Option	Space Cab	Super Space Cab
Exterior:		
Cab suspension mechanical	•	•
Electrically heated mirrors (except kerb view mirror)	•	•
Electrically adjustable mirrors (except kerb view mirror)	•	•
Halogen headlamps with Lexan lens	•	•
Anti-theft system	•	•
Corner air deflectors	•	•
Sun visor	-	integrated
Interior:		
Electrical operated windows	•	•
Electric door lock co-driver	•	•
LCD info panel	•	•
Comfort air driver seat	•	•
Airco	•	•
Auxiliary heater (air)	•	•
Accessory connector	•	•
Optional:		
Cab suspension air	•	•
Sun visor	•	standard
Xenon headlamps	•	•
Skylights	-	•
Electric door locks with remote control	•	•
Fleet Management System (FMS) connector	•	•
Automatic temperature control	•	•
Pocket sprung lower bunk matras	•	standard
Second (upper) bunk	•	standard
Refrigerator	•	•
Dashboard trim aluminium look or wood structure	•	•
Steering wheel leather	•	•
Airbag driver and seat belt tensioners both sides	•	•
		

Depending on the vehicle configuration a specific option may not be possible. The availability and specification may differ per country. For further information please contact the DAF organisation. Subject to modification without prior notice.

XF105 series cabs

General information

Active safety

The active safety features incorporated in the DAF XF105 cab help prevent accidents or injury by optimising conditions for the driver. An alert driver in a comfortable environment is far less likely to be involved in an accident.

The ergonomic design of the XF105 cab allows the driver to give maximum attention to the road and the other traffic. The cab ergonomics are not restricted to the design and position of the controls and displays, but also include an excellent visibility by large windscreen and side window areas and large vibration-free rear view mirrors.

The comfortable seating position and the low interior noise level help a great deal to prevent driver fatigue.

A relaxed and safe ride is further enhanced by vehicle systems like VSC (Vehicle Stability Control) and EBS (Electronic Brake System).

Passive safety

Passive safety features built into the DAF XF105 cab help protect the occupants of the vehicle in the event of an incident. They include an integral steel safety cage as part of the cab structure.

The cab design also comprises integral knee protection for drivers and co-driver.

Three-point safety belts and head rests are integrated in the driver and co-driver seats. A seat belt reminder system alerts a driver who drives off without being buckled up.

An airbag in the steering wheel, combined with seat belt tensioners for both the driver and the co-driver, is optional.

The safety of other road-users is taken care of by the underrun protection and the large field of view from rear view mirrors.

Aerodynamics

Air management kits for the DAF XF105 improve the aerodynamic efficiency and therefore reduce the fuel consumption. The net result is more earnings per kilometre. They also enhance the overall appearance of the vehicle and thus contribute to a positive image of the operator.



The air management options for the XF105 Space Cab and Super Space Cab include fixed or adjustable roof spoilers and side collars. Chassis side skirts for tractor models may complement the cab aerodynamics.

DAF air management parts have been developed in a wind-tunnel to ensure maximum efficiency in combination with the cab.

Painting process

The high-quality durable finish protects the exterior of the vehicle for its full operational life, and helps maintain its value for a higher return on investment. To obtain a highly corrosion-resistant finish to the cab, double-sided hot-dip galvanized steel is used for the inner and outer door panels, the cab rear wall and various brackets and sections in exposed areas.

The metal parts are then degreased and treated with zinc phosphate before receiving a cathodically applied primer followed by a filler coat. The underbody is treated to a PVC-based coating and then the entire cab is painted with a two-component polyurethane topcoat.

Finally, wax fluid is sprayed into box sections and cavities for extra corrosion protection.