

Specification sheet



A PACCAR COMPANY

FTG CF85

6x2 tractor

Engines

CF85.360; 265 kW
 CF85.410; 300 kW
 CF85.460; 340 kW
 CF85.510; 375 kW

GVM

24600 kg
 Max. front¹⁾: 7100 kg
 Max. rear: 18600 kg

GCM

44000 kg



	Wheelbase - AE		Unladen weight ²⁾			Gross Carrying Capacity			Variable dimensions									
	WB	AE	Front	Rear	Total	Front	Rear	Total	AC	CE	CH ³⁾	KA ⁴⁾	KA ⁴⁾	TL	HA ⁵⁾	HA ⁶⁾	TK ⁷⁾	TW ⁸⁾
Day	3,98	0,96	4979	3020	7999	2121	15580	16601	0,39	4,55	1,96	0,72	0,95	6,32	0,99	0,96	15,12	16,46
Sleeper	3,98	0,96	5049	3030	8079	2051	15570	16521	0,82	4,12	1,96	0,71	0,93	6,32	0,99	0,96	15,12	16,46
Space	3,98	0,96	5174	3030	8204	1926	15570	16396	0,82	4,12	2,63	0,68	0,91	6,32	0,99	0,96	15,12	16,46

Other dimensions VA: 1,38 WV: 1,32 WB+: -0,50 HV⁹⁾: 0,97 HV¹⁰⁾: 0,91 RB: 0,79 SB: 1,82 TB: 2,45

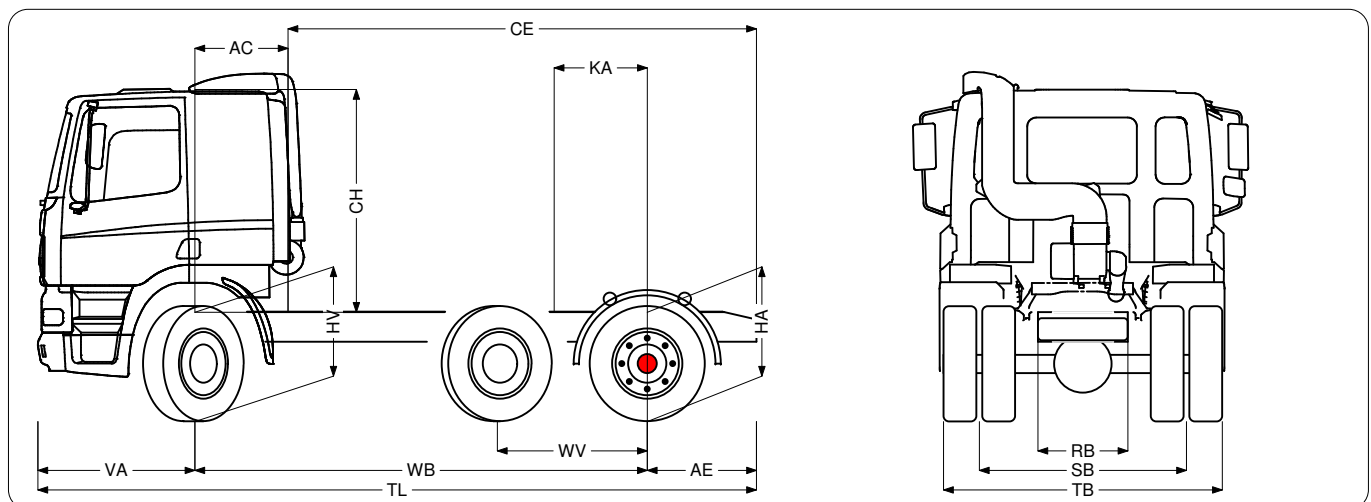

1) Axle load with standard tyre size.
 2) Chassis and Cab Weight calculated with: Standard specification items only with 390 litres of fuel, 15 litres of AdBlue and driver of 80 kg, tolerance ± 3%. Changing of the specification can have major impact on vehicle weight.
 3) Cab height is measured from frame member to closed cabin roof hatch. With air intake on cab roof: +0.14 m.
 4) Calculate customer specific KA with TOPEC.
 5) Unladen height at centre of driven axle (leading axle down).
 6) Laden height at centre of driven axle(s).
 7) TK = turning circle between kerbs.
 8) TW = turning circle between walls.
 9) Unladen height at centre of front axle(s).
 10) Laden height at centre of front axle(s).

FTG CF85

Cab exterior

Mechanically suspended Sleeper Cab with steel bumper, tinted glass and electric window openers. Main mirrors and wide angle mirrors electrically heated.

Mechanically controlled roof hatch. Cab width 2300 mm; Electric door lock co-driver, 2 keys; Engine immobiliser with fuel injection inhibit; Front view mirror; Halogen head lights.

Optional:

- Day Cab
- Space Cab
- Electrically adjustable mirrors
- Xenon head lights with washer
- Combi lights in bumper
- Fog lights front

Aerodynamics

Optional:

- Side collars
- Various types of roofspoilers and settings

Colours

Cab colour H3279 Brilliant White; C4P500GRY Chassis colour grey.

Optional:

- Mirror covers in cab colour

Cab interior

Right-hand drive (RHD); Tachograph digital, Stoneridge; Speed limiter setting 85 km/h; Dashboard: black finish; Driver seat: Comfort Air; Co-driver seat: fixed; Seat belts; Lower bunk, raised 135 mm; Auxiliary cab heater (air).

Optional:

- Soft grip steering wheel, leather finish
- Dashboard: aluminium look
- Dashboard: wood structure
- Refrigerator
- Timer for auxiliary cab heater
- Various types of drivers and co-drivers seats
- Air conditioning
- Automatic temperature control

Communication and driver support

Speaker system with 2 speakers; Antennas: 1x GSM.

Optional:

- FMS connector prepared
- Prepared for DAF telematics (DTS)
- Various makes and types of audio equipment
- Handsfree telephone kit
- Lane Departure Warning system
- Vehicle stability control
- Reverse warning

Suspension and axles

Front axle type 152N, 100 mm vertical offset. Parabolic leaf suspension with shock absorbers and stabiliser. Max. load 7.5 tonnes; Leading rear axle 150N; Driven rear axle and non-driven steered leading rear axle with adjustable electronically controlled air suspension, including shock absorbers and stabiliser. Driven single reduction axle type SR 1347 with 4 air bellows, max. load 11.5 tonnes. Leading axle with 2 air bellows, max. load 7.1 tonnes; Lifting device for auxiliary axle; Load limiter 11.5 t.

Optional:

- Axle load monitoring

Wheels and tyres

Front axle 1: 295/80R22.5; Front axle 2: 295/80R22.5; Rear axle 1: 295/80R22.5;

Wheel colour: silvergrey; Wheel protection rings silvergrey.

Optional:

- Disc wheels steel, black
- Wheels aluminium Alcoa Brushed 32 mm
- Wheels aluminium Alcoa Dura-Bright 32 mm
- Wheels aluminium Alcoa Mirror Polished 32 mm
- Wheels aluminium Speedline 32 mm, satin gloss
- Various tyre makes and types

Driveline

MX engine: 12.9 litres, 6 cylinder diesel engine. Engine performance according to ECE R24-03: output 265 kW (360 hp) at 1500-1900 rpm. Torque 1775 Nm at 1000-1410 rpm. Max. ambient temperature 38 degrees Celsius. Exhaust emission aftertreatment with SCR technology (selective catalytic reduction); Manual gearbox, 16 speeds; Manual, 16-speed, 16S1900; Gearbox ratio 16.41-1.00; Rear axle ratio 2.93; Mechanical differential lock; ASR; Traction control 15.0 t.

Optional:

- 410 hp / 300 kW
- 460 hp / 340 kW
- 510 hp / 375 kW
- Automated, 12-speed, 12AS1930
- Automated, 12-speed, 12AS2130
- Automated, 12-speed, 12AS2330
- Automated, 12-speed, 12AS2530
- Automated, 12-speed, 12AS2540
- Manual, 16-speed, 16S1800
- Manual, 16-speed, 16S2000
- Manual, 16-speed, 16S2200
- Manual, 16-speed, 16S2300
- Manual, 16-speed, 16S2500
- Clutch protection

Brake system

Parking brake control + test position; Dual circuit full air brake system. Disc brakes front and rear (drums for rear axle with hub reduction). Twin cylinder air compressor with heated air dryer, 670 l/min at 10 bar. Electronic Brake System; ABS.

Optional:

- MX Engine Brake
- ZF Intarder
- Spring brake cylinders on the first front axle

Chassis

Wheelbase 3.98 m / rear overhang 0.96 m; Side member height 260 mm; Side member 7.0 mm, front reinforcement; Exhaust discharge to the right-hand side; Steel fuel tank 390 l, height 580 mm; Rear mudguards; Spray suppression; Front underrun protection (FUP); For available heights, thickness and inner reinforcements see chassis drawings; Catwalk with step.

Optional:

- Various material / fuel tank size combinations

Drawbar and trailer equipment

Fifth wheel Fontaine 210, pressed steel; Fifth wheel KA dimension 860 mm; Lead-up ramps; Pneumatic trailer connection C-type; Electric connection 24 V / 2x7 pins.

Bodies and preparations for bodying

Application connector on the cab front.

Optional:

- Engine speed control connector cab front
- Engine speed control connector chassis
- Application connector on the chassis
- Tipper prep with control airlines to the cab

Power take-off (PTO)

Optional:

- Various types of PTO's / position combinations

Electrical power supply

Alternator 80 A, batteries 2x 175 Ah.

Optional:

- Alternator 110 A
- Batteries 2x140Ah
- Batteries 2x225Ah

Legal aspects

Exhaust emission Euro 4.

Optional:

- Exhaust emission Euro 5

Application conditions

Moderate climate, temp not below minus 18 deg C; Maximum ambient temperature 38 degrees; Air intake on the cab roof; 6x2G.

Optional:

- Coolant filter
- Cyclonic air intake behind the cab
- Oil cooler gearbox
- Coldstart device

Service and maintenance

Optional:

- Service interval extended

Vehicle delivery

Minimum toolkit.

Reference Notes

Available fuel tanks are NOT relevant to all wheelbase/cab combinations. Day Cab as per Sleeper Cabs but excludes: Night heater and bunk but includes storage behind seats. Space Cab as per Sleeper Cab but includes: Overhead and increased under bunk storage and cyclonic air intake behind the cab.

Depending on the vehicle configuration a specific option may not be possible. The availability and specification of this vehicle may differ per country. For further information please contact the DAF organisation. Subject to modification without prior notice.